



INDUSTRIAL EMERGENCY FLUORESCENT LUMINAIRE

APPLICATIONS

- | Oil, gas and petrochemical industry
- | Food industries
- | Agriculture
- | Distilleries, water pumping stations and sewage treatment works
- | Marine workshops & machinery rooms

CERTIFICATION AND APPROVAL

Ingress protection to IP65
to EN60529

Designed & manufactured to EN60598-1

FEATURES AND BENEFITS

- | Lamp options 18W, 36W and 58W
- | Copper & Iron pulse start control gear
- | Maintained or non-maintained operation
- | Comprehensive range of lamp options
- | Internal battery
- | Simple to install & maintain
- | Lightweight and slim line construction
- | 3 hours emergency duration



Electrical Products

Victor Lighting PO BOX 5571, Glasgow G52 9AH
Tel: +44 (0) 141 810 9644 Fax: +44 (0) 141 810 9642
Email: info@victor-lighting.com
www.victor-lighting.com

INDUSTRIAL AREA FLUORESCENT LUMINAIRE

TECHNICAL SPECIFICATION

LAMP TYPES

T8 Bi-pin Lamps:
18W (600mm luminaires)
36W (1200mm luminaires)
58W (1500mm luminaires).

POWER SUPPLY

230V/240V, 50Hz

POWER FACTOR

Greater than 0.95

TERMINALS

Suitable for up to 4mm² conductors. Terminals for live, live switched, neutral, earth. Internally earthed.

CABLE ENTRIES

Pre-drilled Ø20mm clearance holes, one at each end.
Supplied with stopper plugs and seals.
Cable glands must be used to maintain a minimum of IP54 rating.

MATERIALS

Body - Corrosion resistant glass reinforced polyester (GRP).
Diffusers - Polycarbonate.
Clips - Stainless Steel.
Gear Tray - White polyester painted zinc coated steel

MOUNTING

8mm clearance holes. sealing washers are provided

CONTROL GEAR

Copper & Iron pulse start ballast

WEIGHT

1 x 18W Lamps	-	4.8kg
2 x 18W Lamps	-	5.2kg
1 x 36W Lamps	-	5.6kg
2 x 36W Lamps	-	6.1kg
1 x 58W Lamps	-	5.7kg
2 x 58W Lamps	-	7.1kg

SUSPENSION

A range of accessories is available including eye bolts, wall and ceiling brackets. Suspension holes suitable for M5 fixings.

DIMENSIONS

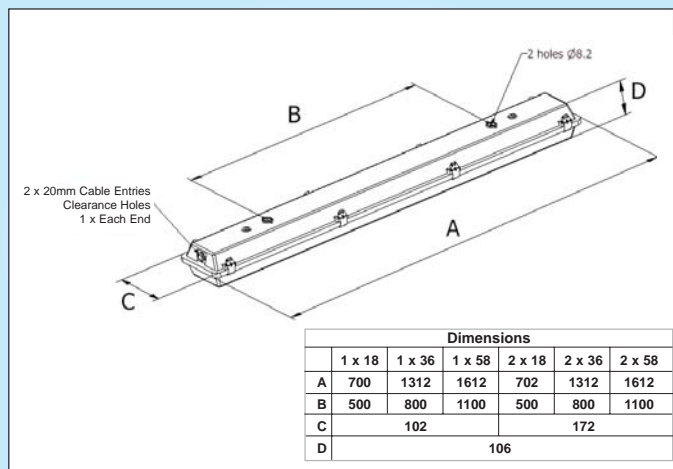

To calculate photometric values for lighting design, please use the free Victor "Lite Guide" software package. To request your copy, please contact your local Victor agent or use the request form on the website.

ORDERING REFERENCE

Std. Cat Ref.	Wattage	Voltage	Lamp Type
MA2I/118/BI/EM*	1x18W	240V 50Hz	Bi-Pin
MA2I/218/BI/EM	2x18W	240V 50Hz	Bi-Pin
MA2I/136/BI/EM*	1x36W	240V 50Hz	Bi-Pin
MA2I/236/BI/EM	2x36W	240V 50Hz	Bi-Pin
MA2I/158/BI/EM*	1x58W	240V 50Hz	Bi-Pin
MA2I/258/BI/EM	2x58W	240V 50Hz	Bi-Pin

* - Emergency single lamp versions only available in a twin lamp body

OPTIONS - SUFFIX TO CATALOGUE REF.

/NM	Non-maintained emergency version (single lamp body)
/MF	Mains fuse
/T	Through wired
/ES	Electronic start
/EA	External earth

ACCESSORIES

Description	Part No
Offset ceiling bracket assembly	S3004-100001
Pole mounting bracket assembly (38/50 diameter poles)	S3004-100002
C' form hook type ceiling bracket assembly	S3004-100003
Flush mounted wall bracket assembly	S3004-100004
18W wall mounting outreach bracket (use with S3004-100002)	NPRO4-0008
36W wall mounting outreach bracket (use with S3004-100002)	NPRO4-0012
58W wall mounting outreach bracket (use with S3004-100002)	NPRO4-0022